

ACURA 50 MARATHON.

1 Liefer-/Transporthöhe: 2400 mm [Delivery/transportation height: 2400 mm] mit Option Türautomatik: 2520 mm [With the automatic door option: 2520 mm] **2** Liefer-/Transportbreite: 2350 mm / bei Option Emulsionsnebelabsaugung oder MAGNUM Magazin: 2670 mm [Delivery/transportation width: 2350 mm / with emulsion mist collector or MAGNUM magazine option: 2670 mm] **3** Bedienöffnung bei geöffneter Tür [Operating access] **4** Störkreisdurchmesser: 550 mm [Interference circle diameter: 550 mm] **5** Ansicht Seitenbeladeeinrichtung [View of side loading device] **6** Werkzeugwechselbereich (*Werte bei max. Werkzeugabmessung): Diesen Bereich für den Werkzeugwechsel freihalten. [Tool change area (*values at maximum tool size): Keep this area free for tool changes.] **7** Kratzbandförderer Abwurftrichter links [Scraper belt conveyor discharge funnel on the left] **8** Tür für Werkzeugbestückung [Door for tooling] **9** Option: Emulsionsnebelabsaugung [Option: Emulsion mist collector] **10** Option: MAGNUM Magazin [Option: MAGNUM magazine]

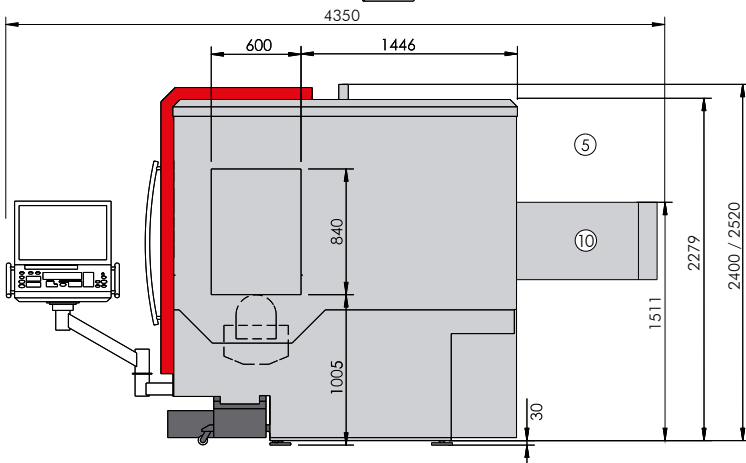
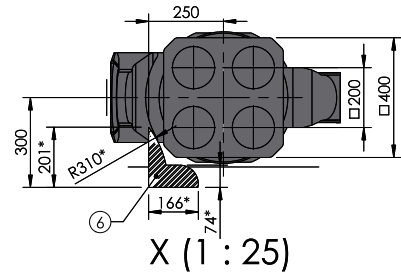
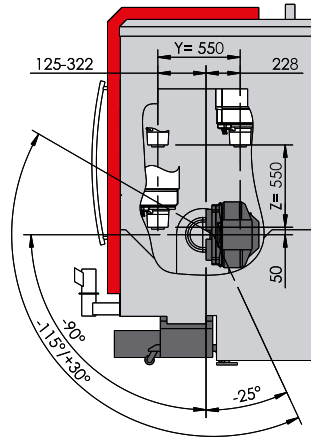
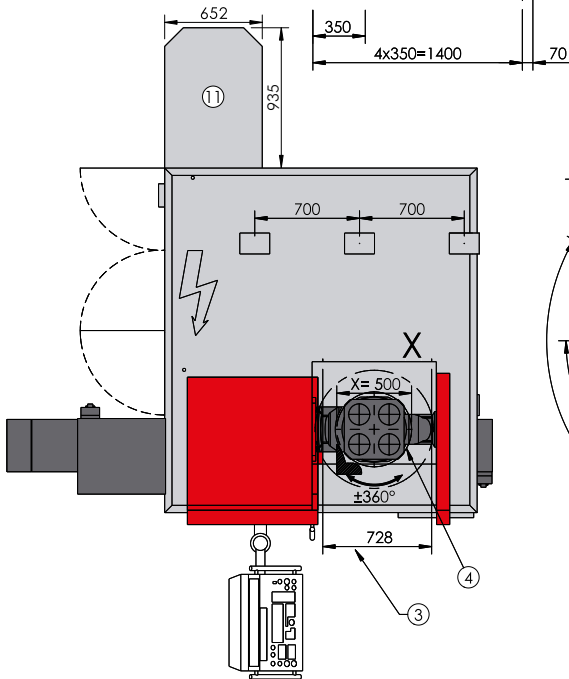
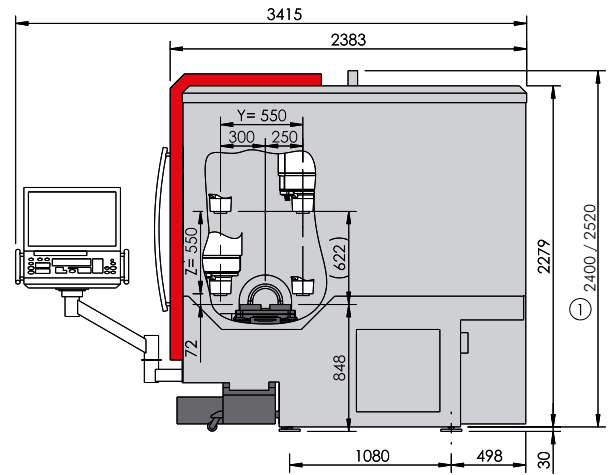
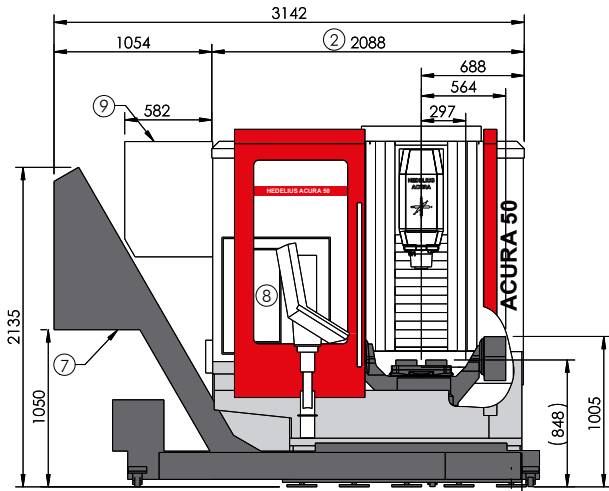

Zeichnungen unverbindlich. Maße können sich ändern und dienen als Richtwert. [Illustrations are not binding. Dimensions are subject to change and serve for orientation purpose.]

MARATHON PL406.

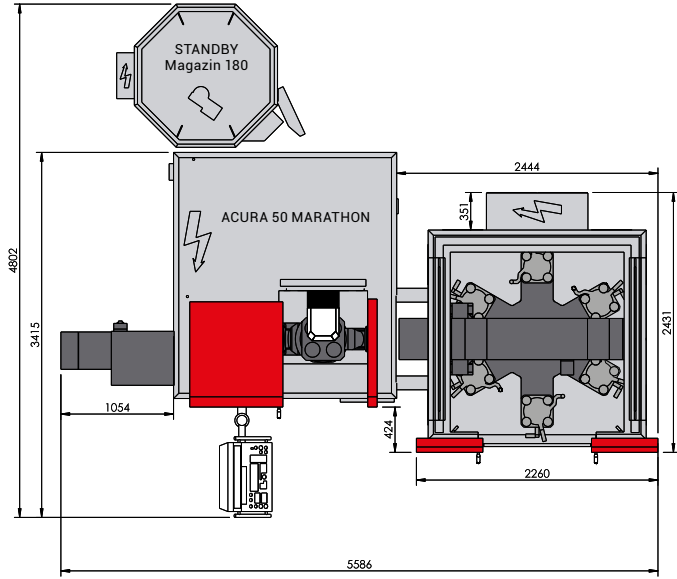

ACURA 50 MARATHON
MARATHON PL406
400 x 400 x 38 mm

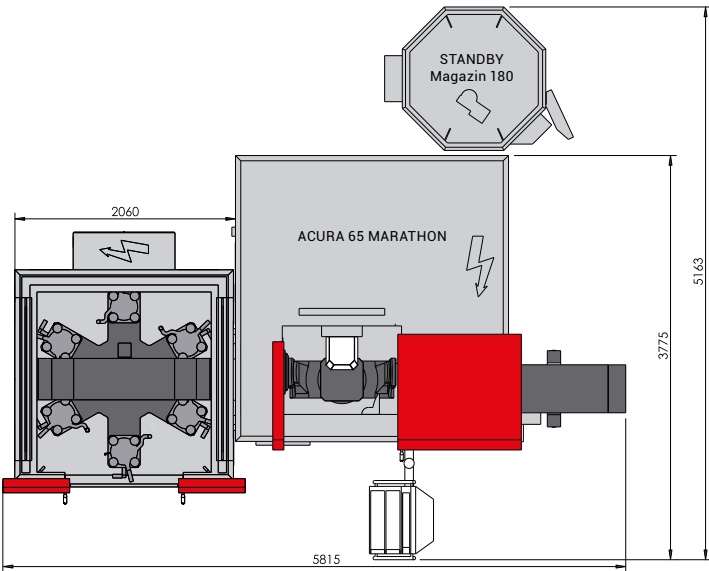
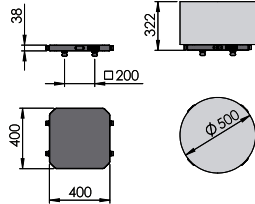

ACURA 65 MARATHON
MARATHON PL406
400 x 400 x 38 mm

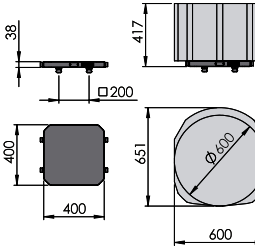

ACURA 65 MARATHON
MARATHON PL406
400 x 500 x 48 mm

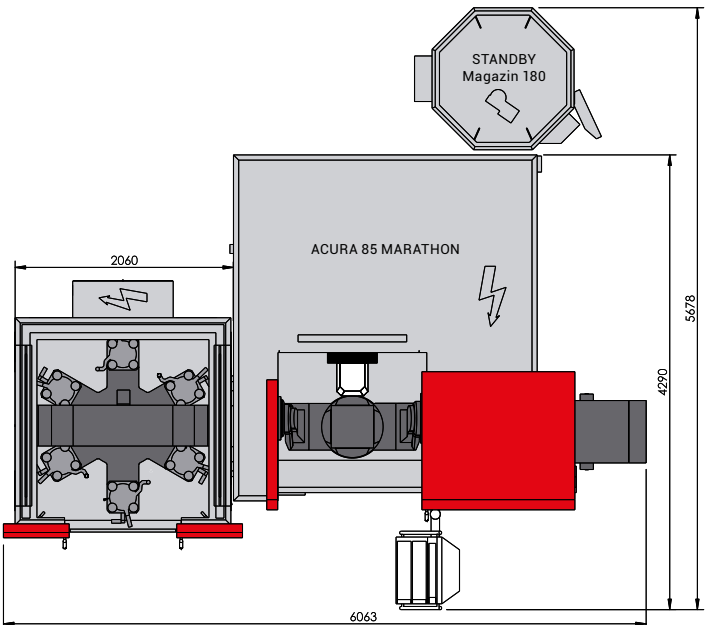
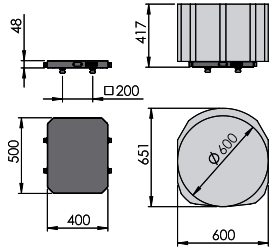

ACURA 85 MARATHON
MARATHON PL406
400 x 400 x 38 mm

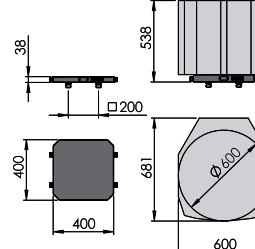

ACURA 85 MARATHON
MARATHON PL406
400 x 500 x 48 mm

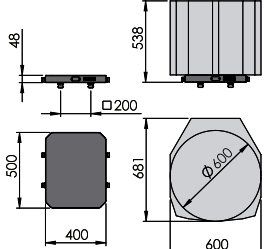

Zeichnungen unverbindlich. Maße können sich ändern und dienen als Richtwert. [Illustrations are not binding. Dimensions are subject to change and serve for orientation purpose.]

MARATHON RZ430.

